



SeQual Technologies Inc.
11436 Sorrento Valley Road, San Diego CA 92121 USA • 858-558-0202 • Fax 858-558-1915

Service Manual for SeQual Integra Oxygen Concentrators

Part Number 2435
Revision F

Table of Contents

Routine Patient Maintenance3

Scheduled Preventive Maintenance3

Troubleshooting Guide4

 Operational problems.....4

 Power problems5

Digital Error Code Guide.....6

Service Section Compressor Assembly8

 Compressor maintenance.....8

 Compressor Rebuild Procedure8

Service Section Pod Assembly10

 Board Calibration Procedure.....10

 Pod Replacement Procedure12

ATF Replacement Procedure.....13

Compressor Inlet Filter Replacement13

Replacement Parts.....14

How to Contact SeQual14

Routine Patient Maintenance

At least once a week clean cabinet intake filter, located on the top of the unit.

1. Remove the filter from the cabinet.
2. Wash the filter in warm water using a mild detergent solution.
3. Rinse the filter thoroughly and squeeze out the excess water.
4. Allow the filter to air dry. *Caution: The filter should be completely dry before using it again, as excess moisture may impair the proper operation of the oxygen concentrator.*
5. Reinsert the filter in the cabinet.



The cabinet intake filter should be replaced as needed. If the Oxygen Concentrator is used in a dusty environment, the filter may need to be replaced more often. **Do Not** operate the Oxygen Concentrator for more than 30 minutes without a filter installed.

Scheduled Preventive Maintenance

12 Months or as needed:

- ◆ Verify proper oxygen concentration. It should be a minimum of 88% at maximum rated flow. While monitoring the concentration, verify that the LED's function properly. Refer to Troubleshooting Guide for further information.
- ◆ Clean inside the unit, as needed using a small vacuum cleaner to remove any accumulation of dust or debris.
- ◆ Replace the compressor intake filter after 10,000 hours of operation or as needed (refer to Troubleshooting Guide). Refer to Replacement Parts section for proper filter.

Troubleshooting Guide

Operational problems

Problem	Probable Cause	Remedy
Concentration is below specification.	Dirty cabinet intake filter.	Clean or replace filter.
	Dirty compressor intake filter.	Replace filter.
	Flow above rated capacity.	Check and adjust flow.
	Worn compressor.	Check compressor according to Service Section.
	Internal leak.	Refer to Service Section.
	Faulty ATF module.	Refer to Service Section.
Yellow LED is on.	Concentration below 85%.	See low concentration above.
	Oxygen sensor needs calibrating.	Refer to Service Section.
Red LED is on and alarm is sounding.	Concentration below 70%.	See low concentration above.
	Oxygen sensor needs calibrating.	Refer to Service Section.
Pressure relief valve purging.	Faulty oxygen module.	Refer to Service Section.
	Faulty relief valve.	Replace valve.

Power problems

Problem	Probable Cause	Remedy
Unit does not turn on.	Unit not connected to power outlet.	Connect power.
	Unit connected but not on.	Check for switched outlet or tripped breaker in building.
	Circuit breaker tripped.	Reset circuit breaker.
	Circuit board malfunction.	Refer to Service Section.
	Power outage.	Check outlet.
	Excessive internal temperature	Check for vent blockage or faulty fan. Allow unit to cool.
Circuit breaker tripped.	Power interruption.	Reset circuit breaker.
	Unit started under pressure.	Reset circuit breaker and wait for flow meter to drop to zero before turning on.
	Faulty internal component.	Refer to Service Section.
Red LED is blinking and alarm is beeping.	Low mains alarm due to loss of power.	Depress power button, reset circuit breaker and turn unit on.
	Excessive internal temperature	Check for vent blockage or faulty fan. Allow unit to cool.

Digital Error Code Guide

In the event there is a malfunction during normal operations of the Concentrator, an Error Code will be displayed on the LCD. These Error Codes, their probable causes, and the suggested corrections are tabulated below.

User Related Error Codes

Error Code	Probable Cause	Remedy
151	Flow rate too low.	Increase flow rate. If problem persists, verify prescription and/or reset limits. Refer to the section on "Board Diagnostic Procedure".
139; 141; 151; 153	Flow rate too high.	Decrease flow rate. If problem persists, verify prescription and/or reset limits. Refer to the section on "Board Diagnostic Procedure".
174; 177	Unit is hot, insufficient ventilation; blocked air intake or air exhaust.	Shut off unit. Remove any obstruction(s) from air openings (refer to section "The Proper Location" in the Instruction Manual P/N 2668) and allow unit to cool. Restart unit.
184	Blocked Oxygen flow.	Shut off unit and find obstruction to outlet. Unkink outlet hose. Replace humidifier. Restart unit.

Service Related Error Codes

Error Code	Probable Cause	Remedy
136; 208	Abnormal Power fluctuation.	Check power source. If problem persists, reset limits. Refer to the section on "Board Diagnostic Procedure".
158	Concentration too low.	Check for leaks among the hoses and fittings. If none found, check the Oxygen Sensor. If Sensor reads correctly, check for worn compressor. (Rebuild compressor if necessary.) If compressor is all right, replace the ATF.
152	Concentration warning. Oxygen concentration did not reach operational level. Flow rate too high.	Turn flow rate adjustment knob clockwise until full stop (closed); then turn knob counterclockwise one full turn. If problem persists, see steps above for Error # 158.

Microprocessor Related Error Codes

Error Code	Probable Cause	Remedy
45; 142; 143; 146 – 148; 155 – 157; 159; 165; 171 – 173; 175; 176; 181 – 183; 185; 186; 204 – 207; 209; 210	Incorrect calibration.	Unit needs to go through the complete Diagnostic Procedure. Refer to the section on "Board Diagnostic Procedure".
1 – 19; 22 – 40; 46 – 49; 130; 150; 161 - 162; 170; 180; 190 - 191; 215 – 230	Processor error.	Shut off unit. Restart unit after 3 minutes. If problem persists, contact SeQual Technical Service.

Service Section

Remove the covers from the unit by removing the four screws in the sides and one in the handle. Spread the covers apart from the top and lift them off.

Compressor Assembly

Compressor maintenance

- 1) Remove the pressure relief valve from the compressor and install a pressure gauge using a ¼" NPT male fitting with a hose connection (SeQual Part No 9151).
- 2) Turn on the unit, set the flowmeter at rated flow and check the compressor pressure. If it is below 18 psig, then check for leaks around the compressor fittings and hoses using Snoop or equivalent leak detection fluid. If no leaks are found, replace the air inlet filter. If the pressure is still below 18 psig, then rebuild the compressor; refer to compressor rebuild section.
- 3) Inspect the spring mounts for uneven wear or damage. Replace spring mounts if necessary using the procedure in the next section.

Compressor Rebuild Procedure

Refer to Replacement Parts Section for proper rebuild kit. Contact Sequal for all other compressor accessories.

- 1) Disconnect the power from the unit.
- 2) Remove the air inlet hose from the barb fitting on the compressor. Leave the fitting in place.
- 3) Remove the heat exchanger coil from the tube fitting. Leave the fitting in the compressor head.
- 4) If replacing the spring mounts, do so at this time. Otherwise, go to Step 6. Remove the two inspection plates on the bottom of the unit and unscrew the four compressor retaining bolts. Lift the compressor off.
- 5) If not rebuilding the compressor, place it on the new spring mounts with the springs oriented as shown in the picture. Be sure the large end of the spring is fully inside the cup on the base. Replace rubber washers on bolts, apply thread locker to the four bolts and install through the mounts and tighten to 36 in-lbs. Install the inspection plates and tighten the screws until they bottom out on the plate.
- 6) Mark the heads with a felt pen to ensure that the head and valve plate are re-installed on the cylinder that they were removed from.
- 7) Remove the cap screws on the heads and pull up on the head and valve plate assembly. Refer to the exploded view in the parts kit.

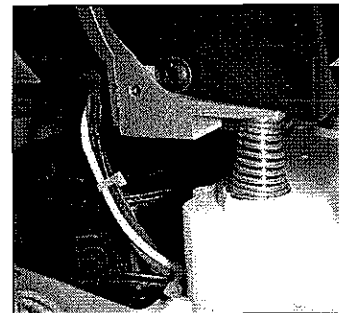

Service Section

Compressor Assembly (continued)

- 8) Separate one of the valve plates from the head and remove and discard the O-ring seals.
- 9) Note the orientation of the valves and remove the valve screws and limiters (if applicable).
- 10) Clean any residue from the valve plate using a water based solvent.
- 11) Install new valves and limiters (if applicable) in the orientation noted in step 7. Torque screws 10-13 in-lbs.
- 12) Repeat steps 6-9 for the other valve plate assembly.
- 13) If not rebuilding the cylinders go to step 19.
- 14) Remove the piston screws.
- 15) Remove the cylinder sleeve, retainer plate and piston cup.
- 16) Place the new cup on the rod, facing up.
- 17) Install retainer plate and torque screws 34-38 in-lbs.
- 18) Rotate the compressor until the rod is at its topmost position.
- 19) Install the sleeve at a 45° angle over part of the retainer. Carefully work the sleeves down over the cup until it is level with the cup.
- 20) Repeat steps 12-17 for the other cylinder.
- 21) Replace cylinder O-rings in the bottom of the valve plate.
- 22) Set the cylinder assembly down into the compressor body, making sure to properly seat the sleeves in the notches of the body.
- 23) Position the valve plates over the cylinders, lining up the cylinder O-ring with the sleeve and the marks made in step 4.
- 24) Install the head O-rings and position the head over the valve plate, again lining up the marks.
- 25) Torque the head screws, working outer to inner, to 48-50 in-lbs.
- 26) Install the heat exchanger and air inlet hose.
- 27) If the compressor was removed, re-install according to Step 5 above, using the picture below for proper installation orientation.

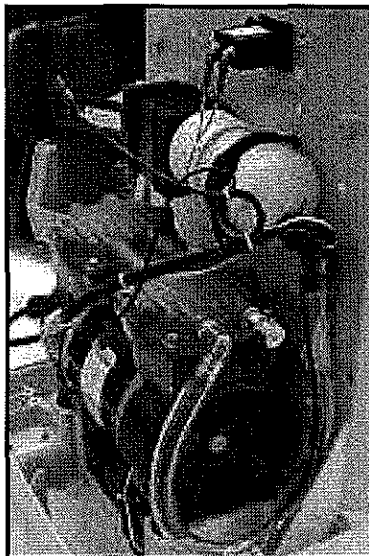

Service Section

Pod Assembly

Board Diagnostic Procedure 5 and 10 Liter Analog Models with Oxygen Monitor

- 1) Turn unit off and remove the covers.
- 2) Connect an Oxygen Sensor to the outlet according to the Sensor manufacturer recommendations.
- 3) Connect a voltmeter to pins one and six of the sensor board.
- 4) Turn on the unit and adjust the flow on the flow meter to the appropriate flow setting for the unit under test.
- 5) Allow the unit to run for five minutes before making any adjustments. If the unit shuts down before the warm up time has elapsed, then replace the Pod assembly (see next section).
- 6) Compare the concentration value on the Oxygen Sensor to the value on the voltmeter. If they are within $\pm 2\%$ and are stable, then no adjustment is necessary.
- 7) If they are out of range, adjust the pot on the sensor. It can be reached with a small thin screwdriver, through the adjustment hole on the front of the pod.
- 8) Turn the pot until the values are equal.
- 9) If it does not adjust or the value is unstable, replace the Pod assembly.

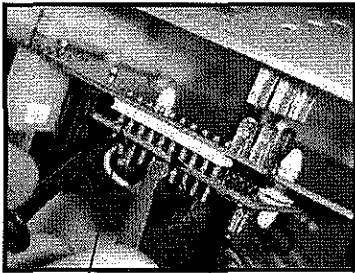

Pin #1

Pin #6

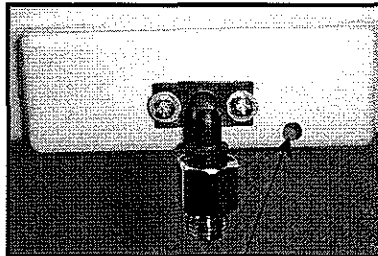

Insert Screwdriver

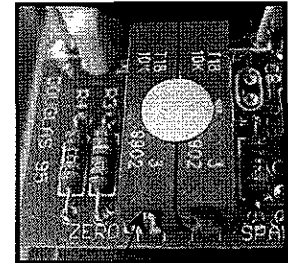

Adjust this screw

Board Diagnostic Procedure 5 and 10 Liter Digital Models with Oxygen Monitor

- 1) Turn unit off and remove the covers.
- 2) Connect an Oxygen Sensor to the outlet according to the Sensor manufacturer recommendations.
- 3) Locate the push buttons on the top back of the circuit board.



Board Diagnostic Procedure 5 and 10 Liter Digital Models with Oxygen Monitor
(continued)

- 4) Press the center button and "Maintenance Mode" will be displayed on the top line of the LCD display. Repeated pressing of the center button will toggle the unit through the various maintenance mode settings. Where applicable, the right button (when viewing from the front) changes the settings. These are:
 - a) **Hour Log** - displays the total run time of the concentrator.
 - b) **Version** - displays the software version of the concentrator.
 - c) **Flow Limit** - displays the maximum allowable flow setting, per patient prescription, and can be adjusted by the technician in 0.5 LPM increments, using the right button.
 - d) **Language** - displays the current language setting, and allows the technician to toggle between the three language choices, using the right button.
 - e) **Show Fault** - displays the last saved fault number and allows the technician to clear the fault, using the right button.
 - f) **Fault Override** - allows the technician to select "halt on fault" or "ignore faults".
 - g) **Flow** - displays the oxygen flow.
 - h) **Concentration** - displays the oxygen concentration.
 - i) **Gas Temp** - displays the temperature of the oxygen in degrees centigrade.
 - j) **Ambient Temp** - displays the room temperature in degrees centigrade.
 - k) **Gas Pressure** - displays the pressure of the oxygen.
 - l) **Line Voltage** - displays the line input voltage.

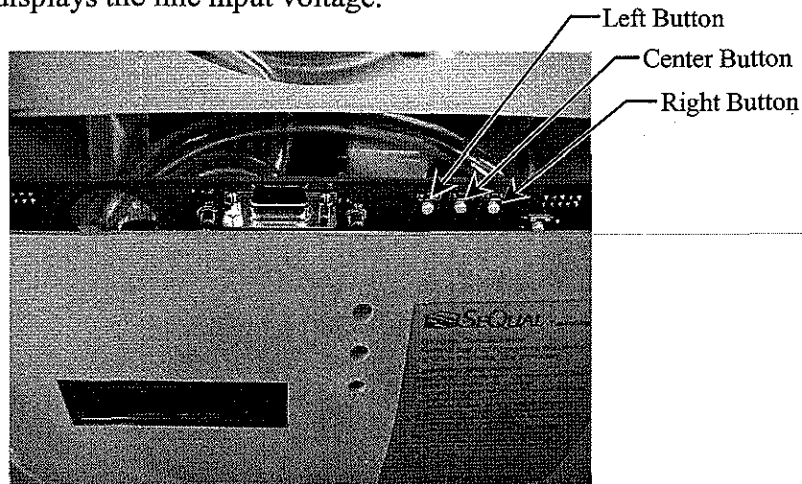

- 5) Press the center button until Flow Limit: is displayed. Press the button to the right (when viewing the front) until the maximum flow rate is displayed.
- 6) Allow the unit to warm up and achieve stable concentration (about 5 minutes).
- 7) Press the center button until Conc: is displayed. Compare the concentration value on the display to that of the oxygen monitor. If the difference is more than 1.0%, contact SeQual for a replacement pod.
- 8) When finished monitoring the concentration, press the button to the left (when viewing the front) to exit Maintenance Mode.

Pod Replacement Procedure

- 1) Disconnect power from the unit.
- 2) Remove the hose from the HEPA filter outlet and temporarily seal the barb on the filter (using tape or a cap) in order to keep the filter clean.
- 3) (For digital models only) Remove the alarm from the center frame. Be sure to remove all excess tape from the center frame. If necessary use isopropyl alcohol to clean the surface.
- 4) Remove the four screws holding the Pod assembly to the frame (see sketch below), holding the Pod to prevent it from falling.
- 5) Turn the Pod over and disconnect the wires (T1 and T2) from the circuit breaker and disconnect the eight-pin plug (J501) by depressing the catch lever and pulling the connector.
- 6) Holding the new Pod close to the final installation position rotate the face downward in order to hook-up the following connectors:
 - a) Connect wire harness 8-pin connector (J501) to PCA. Align the clip side of the connector with the PCA connector having the catch (bump) on the side.
 - b) Connect the black or brown wire terminal (T1) to the bottom connector tab on the circuit breaker.
 - c) Connect the brown wire terminal (T2) to the top connector tab on the circuit breaker.

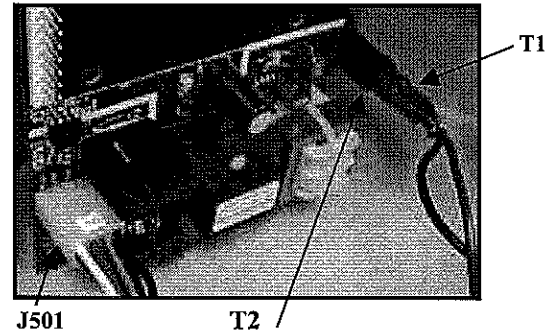

Rotate the Pod upright and align the four attachment points (see sketch) with the appropriate holes on the center frame and push into place. Secure Pod to Frame at each hole using 1 each **Screw (2414)** and **Washer (3026)** pushed through the hole from the Pod side of the frame. Secure on the backside of the frame with 1 each **Washer (3026)** and **Nut (2316)**. Tighten screws with Phillips #1 Bit (For digital models only). Mount the alarm in the curvature toward the top left side of the center frame. Be sure that the alarm opening is facing the back of the unit as shown. Use the double-sided tape that is already applied to the alarm for securing the alarm to the center frame. Make sure the mounting surface is clean. If necessary, use isopropyl alcohol to clean the surface.

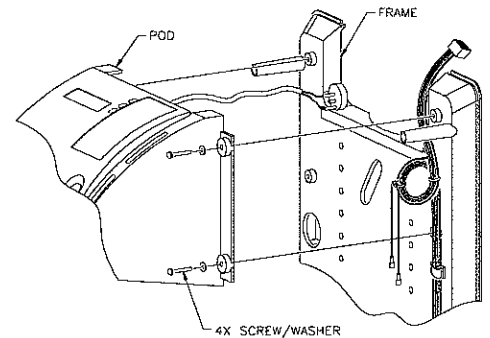

Route the loose end of PVC Tubing through the center frame angled oval opening. Remove the seal from the ATF HEPA Filter Barb. Slide one **Hose Clamp (2311)** over the loose tube just routed from the Pod. Push the end of the tube onto the barb until it hits the stop. Position hose clamp behind step in barb.

Ensure all three Cable Clips that hold the wire harness on the center frame are pushed closed and hold all wires. Replace if necessary.

ATF Replacement Procedure

Disconnect the power connector, shown in the picture, by pressing the locking tabs and pulling the housings apart. Remove the four screws holding the toe clamps to the ATF. Remove the two hoses from the ATF and cover the barbs using the plastic caps from the new ATF. Do not leave the barbs uncovered for more than five minutes. Lift the ATF out of the basket. Set the new ATF in position as shown in the picture. Attach the hoses and tighten the clamps to 100 in-oz. Install the toe clamps on the ATF and tighten the screws to 28 in-lbs. Connect the power connector.

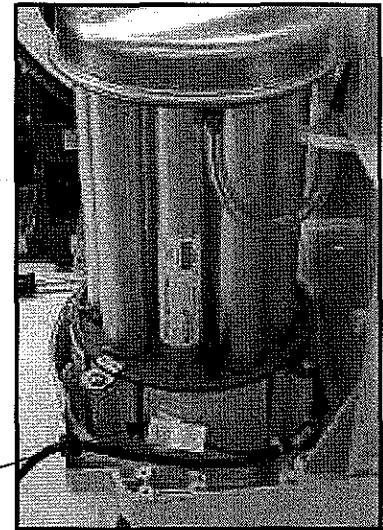

Compressor Inlet Filter Replacement

Remove the hook and loop straps from the Filter/Muffler assembly. Hold the white muffler and twist and pull the filter to remove it. Insert outlet tube on Filter (2607) into the hole on the Muffler. Rotate the filter so that the two parts are roughly lined up across the top length. Push the Filter into the Muffler until the two parts touch.

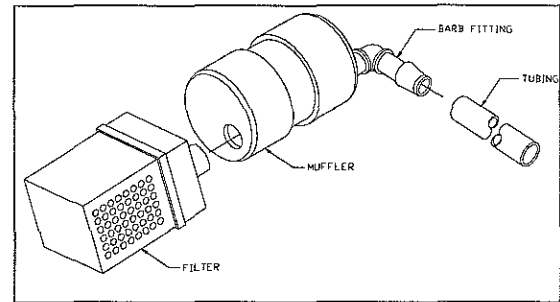

Place the Filter/Muffler assembly in the installed position (as shown below and in picture on page 9) and loop the straps over the assembly. Fasten the assembly by securing the ends of both straps and ensuring that they both cover and attach to the strap pads. Ensure the free end of the PVC Tubing is on the compressor Air Inlet Fitting barb.

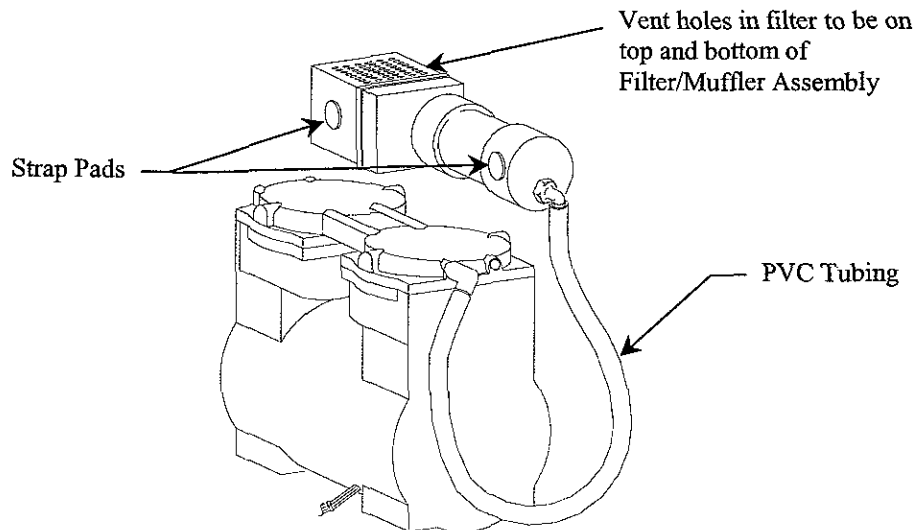

Preventive Maintenance Parts

Description	SeQual Part Number
Cabinet Intake Filter	2185
Compressor Inlet Filter	2607
HEPA Filter	2033
Compressor Rebuild Kit	3197, 3418
Pressure Gauge Test Fitting	9151

Recommended Spare Parts Inventory

Description	SeQual Part Number
Pod Assembly	Refer to Parts Manual or call for correct replacement part. Specify Model Number when ordering parts.
Compressor Assembly	
ATF Module	

If you need any additional assistance, contact Customer Service.

By mail:

SeQual Technologies, Inc.
11436 Sorrento Valley Road
San Diego, CA 92121 USA

By telephone: 858-558-0202 or toll-free in the United States at 1-800-826-4610

By facsimile: 858-558-1915

By E-mail: techsupport@sequal.com